

uSign™ 200

Signature Capture Pad

Signature Capture

ID TECH introduces uSign™ 200, an electronic signature capture device with a graphic LCD display. Users can view their signatures in real-time during the signing process. The graphic display provides interactive text and pen-tap function selection allowing customers to select and navigate transactions with the stylus. Signatures are compressed and provided to a host system for signature and data storage.

Speed and Efficiency

The use of electronically captured signatures has become a common practice in Point of Service (POS) applications. Electronic signature reduces transaction time, eliminates sorting and sending paper, provides convenient electronic storage and transmission, and gives legal accountability (non-repudiation) for POS transactions. The POS applications include retail, hospitality, self-service, and quick-service restaurants.

A Convenient Package

The LCD and touch sensitive screen are housed in a rugged plastic case. The case provides a tethered non-electronic stylus. A metal mounting plate secures the uSign™ 200 case to a desk or counter top when required. A palm rest area below the signature panel provides support to make the signing process easy.

Features and Benefits:

- Electronic signature capture with buffered signature capability
- Replaceable tethered stylus, passive type stylus
- Resistive touch pad
- Sampling rate up to 190 dots per second
- Touch pad resolution 1024 dots per inch
- Real time signature capture with 5:1 compression rate
- Raw data output available
- Firmware filters spikes and electronic noise
- Real-time graphics display of signature during capture
- Host control graphic and text display
- Calibration mode and functions
- Command and response driven operations through an API
- Demo application runs in Windows environments



IDTECH®
Value through Innovation

uSign™ 200 Specifications IDUA-XXXXXX

Electrical

Power Requirements:	5VDC at 150mA 120V AC adapter or USB host terminal port
Interfaces:	RS-232, Baud rate from 1200 to 115200 USB CDC, 2.0 Full Speed

Environmental

Operating Temperature:	1°C to 45°C (34°F to 113°F)
Storage Temperature:	-10°C to 70°C (14°F to 158°F)
Humidity:	10% to 95% non-condensing

Reliability

MTBF:	200,000 POH calculated (Bellcore standard)
Approvals:	FCC Class B, CE, RoHS
ESD Immunity:	4KV to 8 kV min, after reset Meets or exceeds IEC 1000-4-2
Warranty:	One year, parts and labor

Mechanical

Dimensions(L) x(W) x (H):	5.75 inches (14.6 cm) x 5.1 inches (13.0 cm) x 1.57 inches (4.0 cm)
Signature Area:	3.5 inch diagonal
Weight:	0.37 kg (0.82 lb)
Touchpad:	Resistive, transparent, pressure-sensitive screen
Display:	3.7 inch STN monochrome LCD
Sampling Rate:	Up to 190 samples per second
Touchpad Resolution:	1024 dpi
Display Resolution:	LCD Resolution: 192 x 64 dots
Dual Color LED:	Signature Pad or Host Controlled

Footprint:

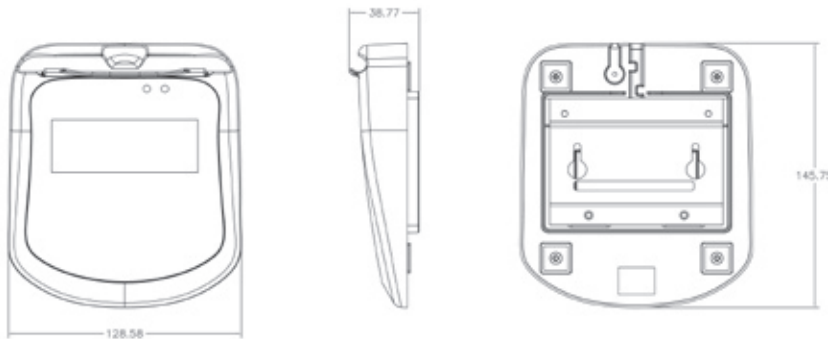

IDTECH®

Value through Innovation

Corporate Headquarters:

10721 Walker Street, Cypress, California 90630
www.idtechproducts.com
(714) 761-6368 sales@idtechproducts.com

International Sales Office

Canada & South America:

+450 465 5261 (Canada) robertop@idtechproducts.com

European Sales Offices:

+49(0) 8851 6159900 (Germany)
emea@idtechproducts.com

ISO 9001 Certified

Legacy Technology Services

We Rent & Sell All Types Of Barcode Equipment

Call now to talk to an expert

866-271-9891

www.LegacyGlobal.com

Some brands we carry



MOTOROLA

Intermec

DATALOGIC™

Honeywell

EQUINOX
PAYMENTS



About us

- Legacy Technology Services is a leading nationwide provider of mobile computing, barcode, printers and point of sale equipment and services.
- For over a decade, thousands of clients across North America have trusted us to provide equipment from leading manufacturers backed by the services to support them.

Latest Hardware from top manufacturers

- Legacy handles virtually every major manufacturer of mobile computing, barcoding and point of sale equipment.

Expert Repair and Maintenance services

- Legacy is one of the best repair facilities in North America

Discontinued product sourcing

- They don't make it anymore? Our inventory also includes manufacturer close-outs and discontinued equipment to support our clients legacy infrastructure.

Trade-in and Disposal services

- That old equipment laying around your facility may still have some value. Legacy routinely purchases equipment from our clients around the globe.
 - Data destruction
 - Hardware disposal
 - Auditing services

Dedicated client account team

- Dedicated, highly trained account managers are here to answer all your questions and provide top notch service.

Equipment rental services

- Sometimes renting is a better solution, Legacy's huge rental inventory provides the equipment you need for temporary needs and projects.



Legacy, Inc.

160 West Road,
Ellington, CT 06029

Toll Free: 866-271-9891

Fax: 888-522-4684